

# BASIC SERIES COMPENSATOR 3.3 L PRODUCT SHEETS

The basic series: A range of cost-effective subsea pressure compensators that feature a light-weight design and volumes ranging from 0.6 to 6 liters.



# OPTION LIST

## A Mounting clamps

The compensator can be delivered including two mounting clamps with threaded ends (M10).

## B Hydraulic connection

Standard hydraulic connection is G3/4". However, other types of connector threads are available on request. Also, tee- and cross fittings can be delivered to increase the number of hydraulic connections as displayed by image B.

## C Pressure relief valve

The compensator can be equipped with a safety valve for protection against internal pressure peaks.

## D Empty detection

Signals that the compensator is (close to) empty.

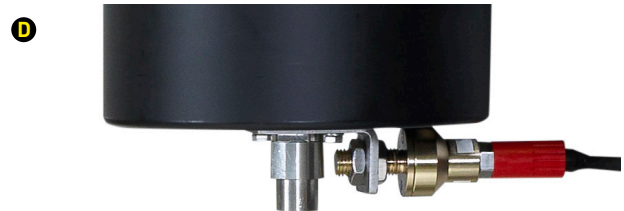

# TYPICAL APPLICATIONS

Subsea equipment for which weight is an important performance criterion, including:

- Subsea instrumentation
- Remotely Operated Vehicles (ROVs)
- Subsea saw systems
- Oil-filled electronics cabinets
- Submerged junction boxes
- Subsea powerpacks



Basic series compensator applied to diver-deployed subsea measurement system.

# BASIS SERIES 3.3 LITRES SPECIFICATIONS

## GENERAL

	METRIC	IMPERIAL
Compensation volume <sup>1</sup>	3.3 liters	0.87 US gallons
Main dimensions	See detailed drawings	
Weight in air excl. oil & mounting clamps	± 6 kg	± 13.23 lbs
Materials (in contact with seawater)	Synthetics, Stainless steel 316L	

<sup>1</sup> The Basic compensator is also available in 0.6, 3.3, 6 liters versions.

## OPERATIONAL

	METRIC	IMPERIAL
Maximum operating depth	3000 m	9843 feet
Operating temperature range	-4°C – +50 °C	27 °F – 122 °F
Storage temperature range	-30°C – +50 °C	-22 °F – 122 °F
Shock resistance	5g, 6 ms	

## HYDRAULIC

	METRIC	IMPERIAL
Design pre-charge pressure	0.15 bar (empty)(min) – 0.26 bar (full)(max)	2.18 psi (empty)(min) – 3.77 psi (full)(max)
Number of hydraulic connections <sup>2</sup>	1	
Hydraulic connection to hydraulic system <sup>3</sup>	1 x (internal) G3/4"	
Pressure relief valve accuracy	20 %	

<sup>2</sup> For more hydraulic connections (for filling, air bleed or safety valve applications) tee- or cross fittings can be mounted.

<sup>3</sup> Compensator can be delivered in with other types of hydraulic connections.

## ELECTRICAL – EMPTY DETECTION

Operating voltage	+10 VDC ... + 30 VDC
No-load current consumption	30 mA typical
Output signal	NO or NC 24 VDC
Connector type	3 pin Subconn micro connector or more

# DIMENSIONS

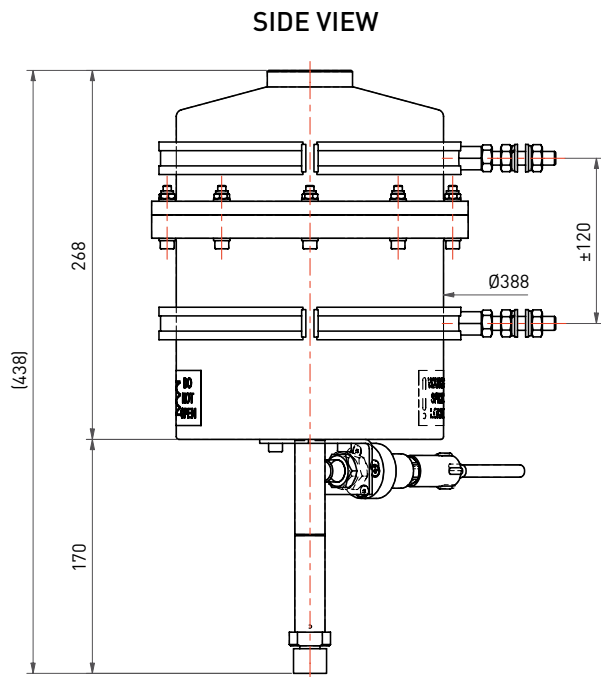
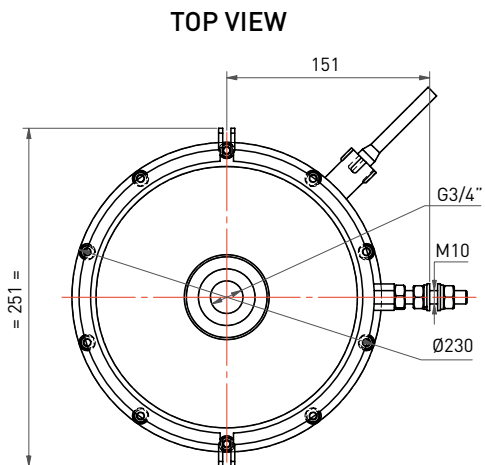

3D CAD files in STEP format are available on [www.seatools.com](http://www.seatools.com)

## RELATED SERVICES

### Client advisory

To ensure that the right size and type of compensator is selected, we advise our clients during the selection process. We do so, taking temperature ranges, pressure ranges, filling levels, entrapped air, fluid behaviors, and other factors into account. In addition, we provide advice regarding the installation and use of a compensator in a subsea hydraulic system.

### Advanced testing programs

Normal factory testing procedures include internal pressure testing, leakage testing, and functional testing. In addition, we also offer more extensive factory testing and qualification programs including external pressure testing, fatigue and life cycle testing, temperature range testing, and contaminat-

tion testing. In addition, the compensator can be delivered flushed to a pre-defined cleanliness level class.

### Custom-made versions

Next to our standardized series, Seatools offers custom-made hydraulic compensators that are tailored to your specifications. Please contact our sales department to request a customized compensator.

### Subsea hydraulic systems

Because of our subsea hydraulic engineering capabilities we are able to fully unburden our customers by delivering complete tailor-engineered subsea hydraulic systems. This includes all related systems such as mechanics, software, electronics, and controls.

**seatools**

Edisonstraat 67  
3281 NC Numansdorp  
The Netherlands  
Tel. +31 (0) 186 68 00 00  
[www.seatools.com](http://www.seatools.com)  
[info@seatools.com](mailto:info@seatools.com)

UNDERWATER SPECIALISTS