



MoorMate – Mooring Monitoring System

System introduction – October 2019

Fundamental design considerations

- ▶ The mooring monitoring system should be capable of:
 1. Monitoring anchor leg integrity
 2. Optional: Monitoring and analyze station keeping performance
 3. Optional: facilitate data acquisition for analyzing mooring system performance
- ▶ Requirements and performance criteria:
 - Robust and durable, more specifically:
 - 20 years design lifetime (subsea)
 - 5 years maintenance interval
 - Able to survive FPSO (mooring line) installation operations
 - Highly reliable alarm. In other words, no or a minimum of false positive alarms
 - A well-serviceable and maintainable system
 - No divers required during complete life cycle (installation, maintenance, and removal)

MoorMate system overview

The MoorMate mooring monitoring system consists of the following:

- ▶ Subsea measurement units, including:
 - Data Acquisition Unit (DAU), containing:
 - Battery pack
 - Subsea electronics module
 - Inclinator and pressure sensor
 - Acoustic transponder
 - Mounting platform to attach DAU with mooring line (platforms for chain, rope, H-link)
- ▶ Acoustic receivers. Deployed by either:
 - Through turret
 - Davit skid and winch
 - Retrievable sensor unit at hull
- ▶ Central electronics cabinet
- ▶ DGPS antennas (optional)
- ▶ Local readout unit or control panel



Figure 1 Impression of a subsea measurement unit.

MoorMate architecture

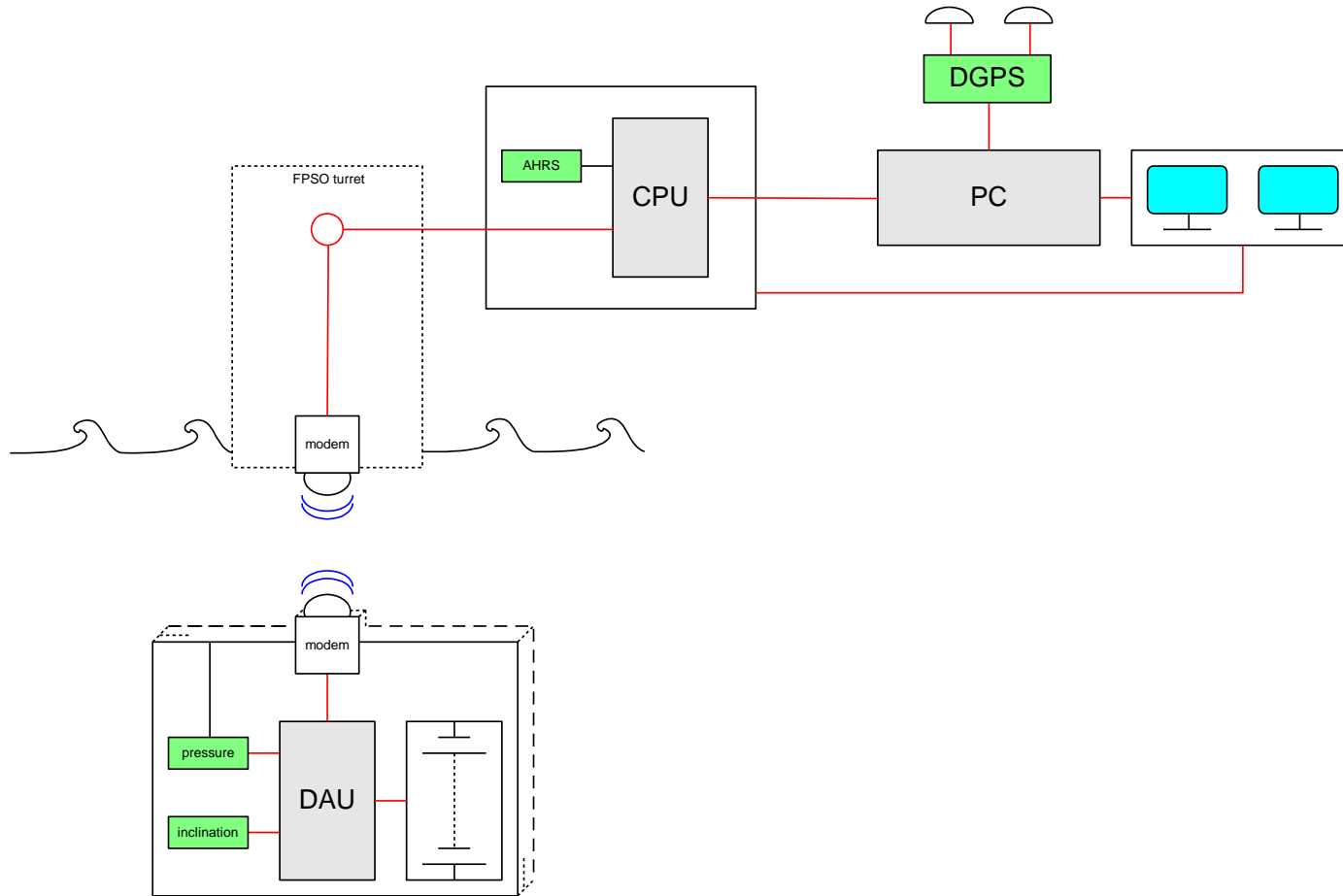

MoorMate working principles

- ▶ Depending on client requirements, the system can be based on up to three independent measurements:
 - Periodic DAU depth measurement by means of a pressure sensor
 - Periodic DAU inclination measurement by means of an inclination sensor
 - Continuous FPSO positional data by means of DGPS (optional)
- ▶ On regular basis (e.g. once per day), the central processing unit (on deck) establishes a connection with the DAU and subsequently retrieves and processes the collected data
- ▶ The system generates an alarm if one, two, or all three measurements indicate a mooring line failure (depending on operator preference)
- ▶ Optionally, in case the (continuously active) DGPS algorithm indicates a mooring line failure, the system can automatically perform an angle and pressure measurement to verify mooring line failure.

Key features MoorMate

- ▶ Reliable mooring line failure detection. Made possible by combining multiple independent measurement techniques
- ▶ Durable and robust design. Made possible by:
 - Synthetic materials used only, therefore no corrosion possible
 - Casted electronics, no water ingress possible
 - No vulnerable connectors or cables
- ▶ Both mounting platform as well as DAU can be installed, maintained, and removed by means of an ROV. This has the following benefits:
 - Suitable for both new as well as existing mooring systems
 - Retrievable for maintenance
 - Subsea electronics not susceptible to loads during FPSO (mooring line) installation operations
 - No divers required during complete lifetime

Performance comparison

		Performance criteria											
		System CAPEX	Ease of installation	Maintainability and repairability	Alarm reliability - false negative	Alarm reliability - false positive	Alarm availability	Allows for mooring analysis	Safety score	Reliability and durability score	Operational attention	Total score	Percentage of #1 score
Weighting factor:		3	1	8	15	11	13	2	18	10	9		
DGPS	Rating	5	4	5	2	2	2	2	5	5	2	299	76%
	Weighted rating	15	4	40	30	22	26	4	90	50	18		
Sonar probe	Rating	1	3	5	3	3	3	3	2	3	3	262	67%
	Weighted rating	3	3	40	45	33	39	6	36	30	27		
Pressure and/or angle measurement (subsea)	Rating	3	2	2	4	4	2	3	2	2	1	228	58%
	Weighted rating	9	2	16	60	44	26	6	36	20	9		
Line tension monitoring through load cell	Rating	1	2	1	3	3	2	3	4	1	1	214	55%
	Weighted rating	3	2	8	45	33	26	6	72	10	9		
(micro) ROV inspection	Rating	4	5	5	5	5	2	1	2	5	1	310	79%
	Weighted rating	12	5	40	75	55	26	2	36	50	9		
Proximity sensors/switches at fairlead	Rating	3	2	1	3	4	2	2	4	2	1	239	61%
	Weighted rating	9	2	8	45	44	26	4	72	20	9		
MoorMate	Rating	2	3	4	5	5	5	4	4	4	4	392	100%
	Weighted rating	6	3	32	75	55	65	8	72	40	36		

MoorMate system upgrades

- ▶ In addition to the basic alarm functionality, the system can be upgraded to facilitate mooring system analysis such as:
 - Analysis of environmental conditions with station keeping performance and anchor leg behavior
 - Long term mooring system behavior
 - Load sharing within mooring cluster
- ▶ Seatools [extensive modelling and software engineering capabilities](#) allow for the development of advanced monitoring and analysis tools, including user interfaces
- ▶ The system can be further extended with an underwater camera system allowing for visual inspection of the mooring lines

MoorMate system upgrades (2)

- ▶ In addition to FPSO mooring system monitoring, the system can be extended for CALM buoy monitoring
- ▶ In this configuration solar powered pods will be installed on the buoy from which data transfer (through Wi-Fi or satellite) can take place between the CALM buoy and the monitoring system on the FPSO

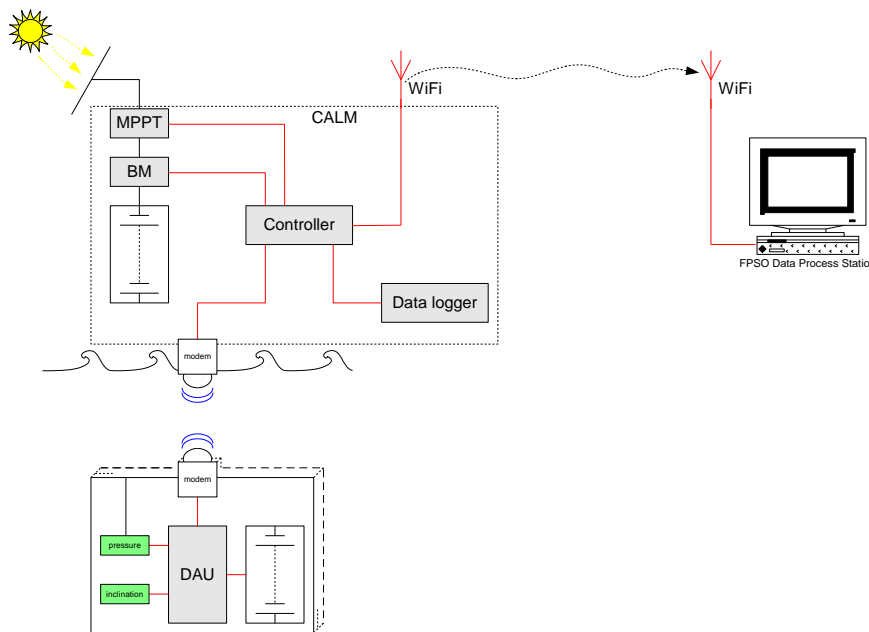

Figure 2 In 2018 Seatools successfully delivered a remote offshore monitoring system for the Ocean Cleanup. Based on the same technology elements CALM buoy monitoring can be performed.

Contact information

Johan Sol

Business development

M. +31651518734

E. jhs@seatools.com